

C A S E S T U D Y  
**PROJECTS**

APPLICATIONS

**05**

CRITICAL ENVIRONMENT

ADVANCING THE SCIENCE OF AIR DISTRIBUTION

Rethink what air management systems can be.  
Revise your notion of functionality.  
Redefine your comfort zone.™



## Comfort, Redefined.

---

Since 1946, Titus has focused on technologically advanced products that create the highest degree of comfort.

We've consistently led the industry by breaking the barriers of expectation and convention when it comes to technology. We've redefined how technology drives, influences and supports air management. And by being first to market with the most innovative approaches to air distribution, we're proud to say that the marketplace has taken notice, and is counting on us to lead the way into the next decade. A challenge we're more than happy to accommodate.

Titus has raised the bar on design, proving that functional can also be beautiful. And we've redefined what it means to be energy efficient, with a collection of smart technology products that optimize the use of natural resources.

Titus has also redefined what it means to work with an air management products partner. We pride ourselves on listening and responding so that we can not only meet expectations, but also exceed them. Service has been, and will always be, our main focus at Titus. And, it's why so many of our customers keep coming back.

**Welcome to your new comfort zone. It starts here.**

## PROJECT - UNLV SCHOOL OF DENTAL MEDICINE

Las Vegas, NV

CLIENT - UNLV

ARCHITECT - CARPENTER SELLERS DEL GATTO ARCHITECTS

ENGINEER - LOCHSA ENGINEERING

CONTRACTOR - SLETTEN COMPANIES

LEED CERTIFICATION - NONE



### ABOUT THE PROJECT

The UNLV School of Dental Medicine is a 2-story, 40,000 square-foot facility designed to teach, prepare and immerse the next generation of students into the field of dental medicine. Students have the opportunity to learn the basics from operating a dental practice to performing oral surgery. Formally an office building, the new state-of-the-art building houses everything needed for new dentists to be successful by incorporating the latest technology into their curriculum and day-to-day work environment.

The main floor of the school contains all of the dental practice and surgical areas. Each area or “pod” as it is commonly known, is designed to focus on one particular aspect of dental medicine which includes the following: pediatric, ortho, endo and perio dentistry. This floor also has a wet lab,





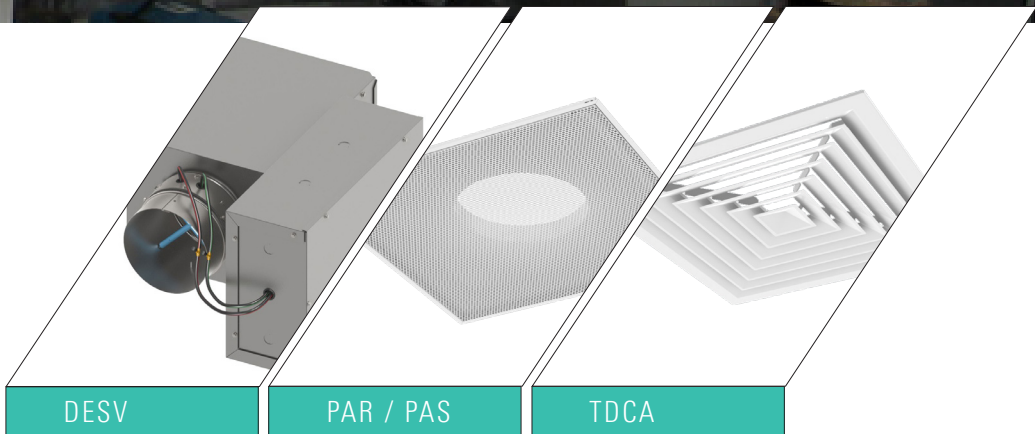

FEATURED PRODUCTS



UNLV SCHOOL OF DENTAL MED.  
interior photos

consultation rooms, administrative offices, and a CT scanner. The second floor mainly houses the classroom environments.

### THE TITUS SOLUTION

Titus has worked with many schools in the creation of their HVAC system, especially those in critical environment applications. We were able to provide several Titus products for the university. The main products featured in the building are the TDCA diffuser, our perforated diffusers, and the DESV single duct terminal unit.

The Titus Series TDC diffusers can handle an unusually large amount of air for a given pressure drop and noise level. Their pleasing appearance harmonizes with various architectural details, especially in modular ceiling systems. Our TDCA diffuser is an adjustable discharge product that contains movable vanes that is accessible from the face of the unit. The discharge pattern of the diffuser can then be adjusted from horizontal to vertical which makes it extremely flexible. The TDCA also maintains an unbroken horizontal flow pattern from maximum cfm down to minimum. All of these features make this diffuser an excellent choice for Variable Air Volume (VAV) systems.

Perforated ceiling diffusers are typically selected to meet architectural demands for air outlets that blend into the ceiling plane. Titus perforated diffusers can be selected for a round pattern to maximize capacity or star pattern to maximize throw. The UNLV School of Dental Medicine utilizes a

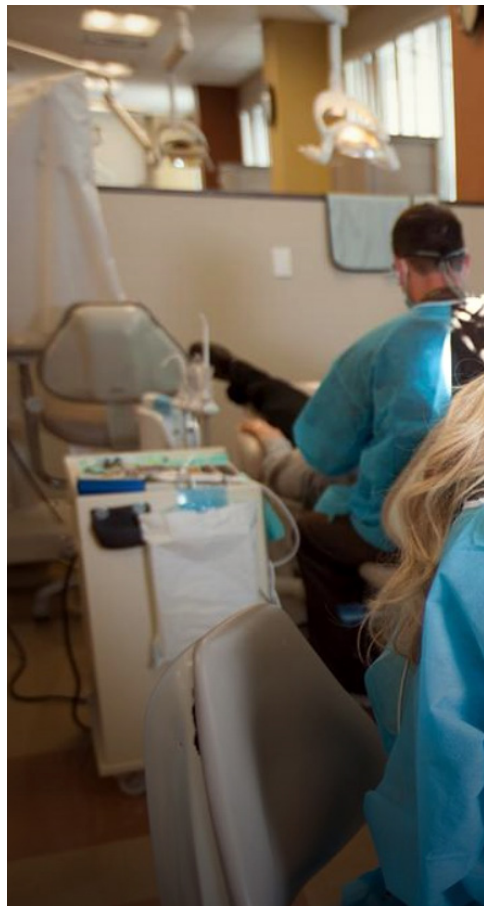

combination of supply and return diffusers (PAS/PAR).

Single Duct terminals are the fundamental building blocks for VAV systems. Their primary function is to regulate airflow to a zone, in response to zone temperature requirements. The Titus DESV is unique as it incorporates many design features that increase performance, decrease service and installation costs, and offer increased value, over and above this basic function.

## THE END RESULT

The new school, which opened its doors in January 2015 was designed to meet the requirements for LEED Gold but actually achieved LEED Platinum Certification and now has a total occupancy of 775 students and staff. With dedicated spaces allotted for day care, early childhood education, play areas and a public library, Amber Trails Community School is a vital piece of a Winnipeg community's puzzle. Thanks to a sustainable design and energy efficient HVAC system, the multipurpose space serves as a daily reminder to students, teachers and the overall community about how buildings can have a positive impact on communities beyond their intended uses.





## PROJECT - UCSD MOORES CANCER CENTER

San Diego, CA

CLIENT - UCSD

ARCHITECT - ZIMMER GUNSUL FRASCA ARCHITECTS LLP

ENGINEERS - POUTNEY CONSULTING GROUP

CONSTRUCTION - McCARTHY

LEED CERTIFICATION - NONE

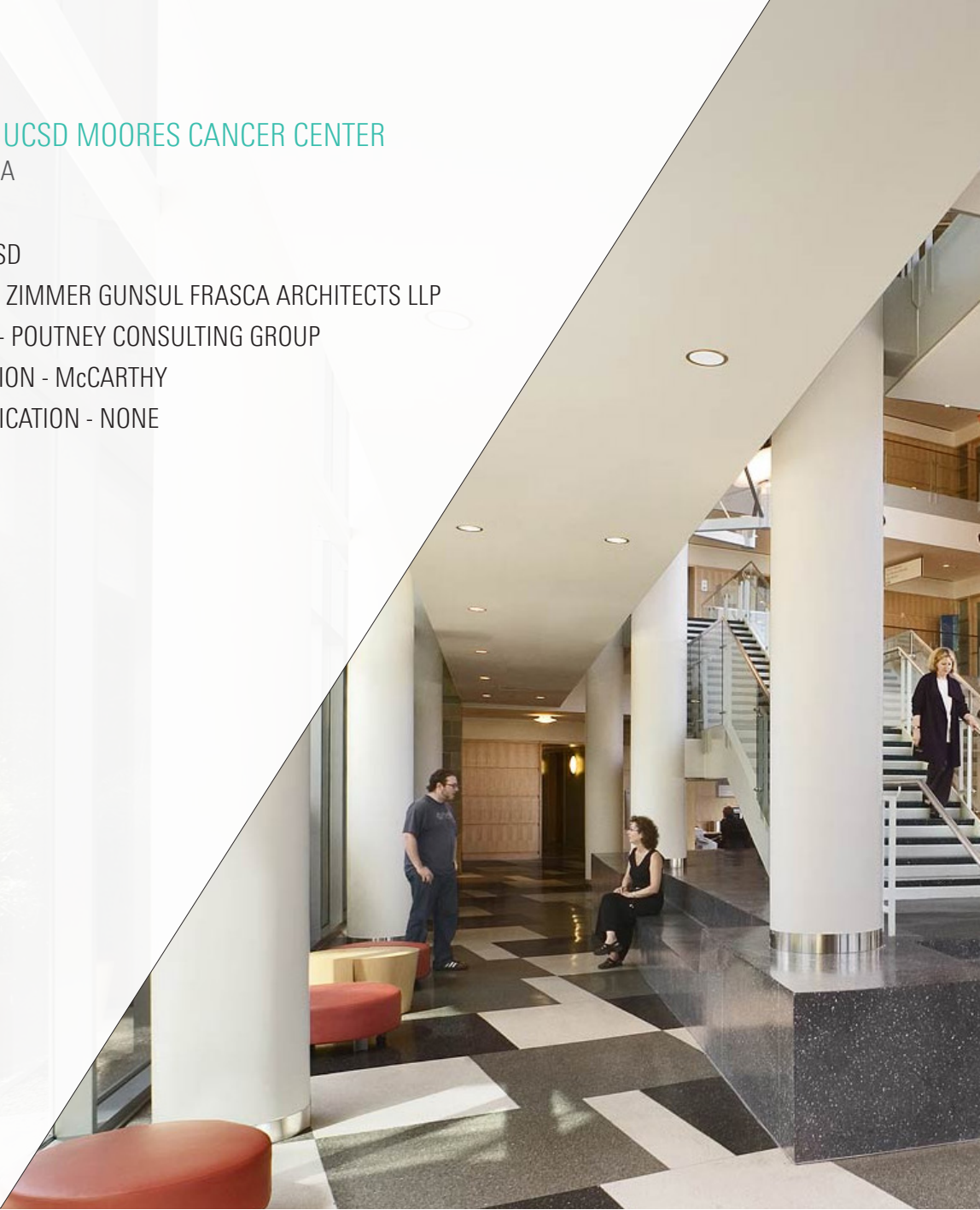

### ABOUT THE PROJECT

The University of California at San Diego Cancer Center is a stunning achievement for teaching, treatment and research into the causes and hopefully cures of all forms of cancer. The patients who walk through these doors will have access to the most advanced care, in a state-of-the-art setting. The groundbreaking work of the physicians and scientists associated with the Moores UCSD Cancer Center will benefit its patients for generations to come.

The UCSD Cancer Center is a 270,000 square-foot facility that houses clinical, research, educational, and outreach activities all under one roof. The center also includes a serene outdoor setting called the Garden of Hope. This tranquil, shaded bamboo garden can be used for dining and interaction





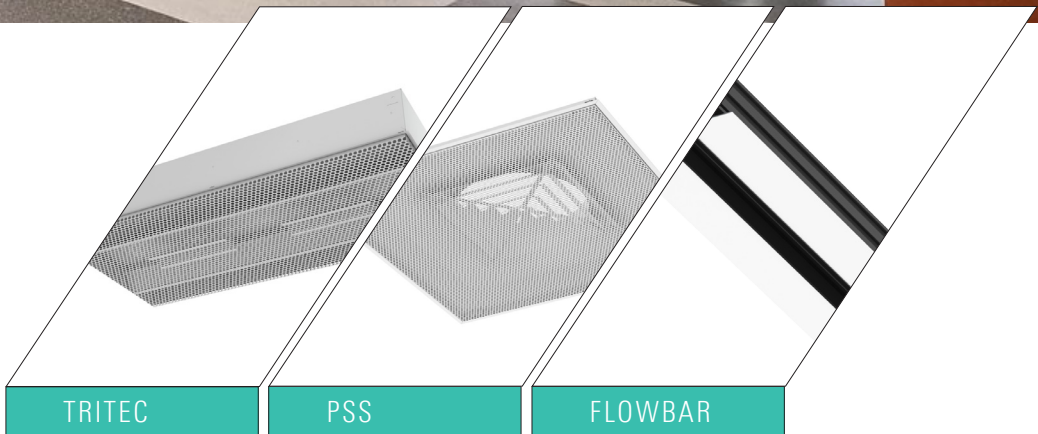

FEATURED PRODUCTS



UCSD CANCER CENTER  
interior photos

with other patients. This location was designed specifically for the cancer patients to inspire hope and provide comfort during their treatment at the facility.

### THE TITUS SOLUTION

Providing air distribution solutions for critical environment or cleanroom applications is not new to Titus. We have been the industry leader for air management for several decades. The products selected for the Moores UCSD Cancer Center were the TriTec, the PSS and the FlowBar.

The Tritec diffuser is a high volume, low velocity unit that utilizes radial air diffusion technology to dilute airborne contaminants. The airflow pattern is designed to produce a uniform pattern to prevent dead spots where contaminants can linger. It is an excellent choice for Class 1,000 to 100,000 rooms. The Titus Series PSS perforated star diffusers generate a high induction air pattern that maximizes throw. The deflector is mounted directly under the neck of the diffuser to generate the long-throw star pattern. As a result, pressure drop and noise levels are lower than typical curved blade perforated diffusers.

Titus FlowBar is an architectural linear diffuser system that maximizes engineering performance without sacrificing aesthetic considerations for the designer. Its outstanding performance allows higher airflows than conventional linear diffuser systems. The wide array of slot widths that are





available allow for more CFM per linear foot while minimizing noise and pressure loss. The Flowbar system is available in continuous linear, incremental linear and square configurations.

FlowBar also provides an installation alternative to the conventional linear diffuser. Conventional linear diffusers are supported by the duct system and in most cases are installed after the ceiling system is in place. For complete ceiling integration, the FlowBar system is offered with a large selection of flange styles compatible with various ceiling applications. Our unique clip/hanger support system allows for quick and easy installations. The system actually supports and becomes an integral part of the ceiling system and is installed along with the ceiling suspension system. This entire series of diffusers is available with two unique pattern controllers.

## THE END RESULT

The new building represents a new beginning for UCSD as an NCI-designated Comprehensive Cancer Center. It is a tribute to the commitment of the university to establish a world-class cancer center that fosters interdisciplinary research and brings the benefits of research directly to the community it serves. The center serves as the benchmark for future facilities to meet or exceed.



## PROJECT - GSU PARKER H. PETIT SCIENCE CENTER

Atlanta, GA

CLIENT - GEORGIA STATE UNIVERSITY

ARCHITECT - CUH2A, INC.

ENGINEER - PBS & J

STRUCTURAL ENGINEER - KSI STRUCTURAL ENGINEERS

CONTRACTOR - McCARTHY CONSTRUCTION

LEED CERTIFICATION - NONE



### ABOUT THE PROJECT

Georgia State University is now the envy of many institutions of higher learning with the addition of their new science and research facility. Designed by HDR Architects to be a lasting landmark for the city, the Parker H. Petit Science Center is a state-of-the-art building that opened in March 2010. The new multi-disciplinary 350,000-square foot facility augments laboratory and classroom space to accommodate an ever-growing curriculum, and enhances the East Side “science zone” of GSU’s urban campus. The new science center offers basic science classes and research labs as well as housing specialized areas which includes: biotechnology, neurosciences, physical therapy, and sports medicine.



The Petit Science Center also has a 20,000 square-foot vivarium and a



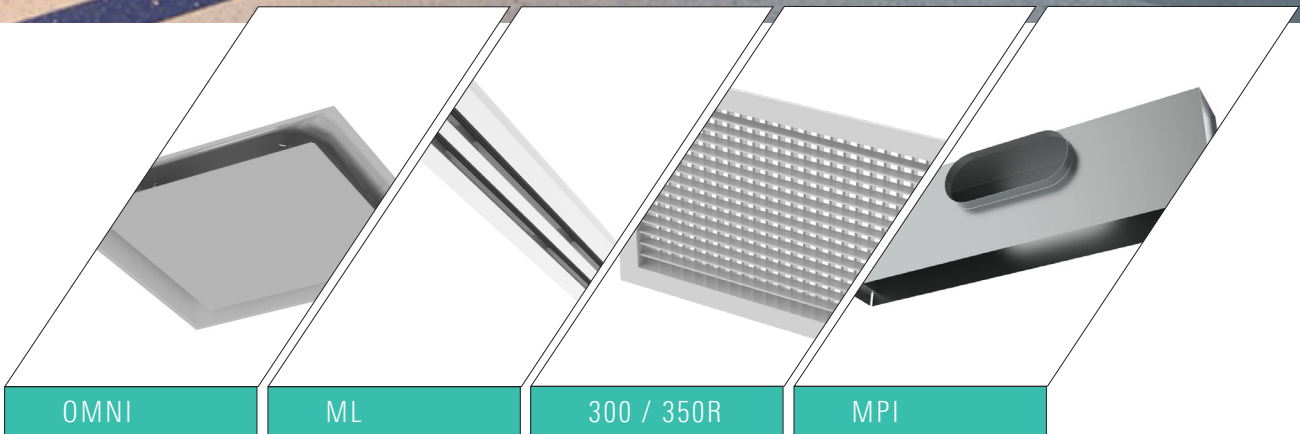

OMNI

ML

300 / 350R

MPI

## FEATURED PRODUCTS



GSU SCIENCE BUILDING  
interior photos

working Bio-Safety Level 4 suite. This makes Georgia State University one of very few universities to have a BSL-4 lab in the country.

### THE TITUS SOLUTION

At Titus, we know that new innovations cannot be created without the proper equipment or in this case, the proper facility. Our air outlets selected for the Parker H. Petit Science Center were not only chosen for their aesthetic appearance, but for their superior performance as well.

The Titus OMNI is a steel Architectural Ceiling Diffuser. This plaque face diffuser satisfies architectural and engineering criteria. Its strong, clean, unobtrusive lines harmonize with any ceiling system without sacrificing performance. The curvature of the OMNI's backpan works with the formed edges of the face panel to deliver a uniform 360 degree horizontal air pattern, without excessive noise or pressure drop. It is an excellent selection for variable air volume systems.

The Titus ML Modulinear diffuser is a high performance, high quality linear slot diffuser. The unique "ice tong" deflector blades allow both changes in air volume and direction from the face of the diffuser. The ML diffuser is also available in 1 through 8-slot configurations. The Titus MPI is an optional plenum for use with the ML modulinear series. When combined with the ML diffuser the MPI provides a tight horizontal air pattern that clings to the ceiling even at low volumes. Titus' 300 / 350 series grilles define the standard





for the industry. With high quality and competitive pricing these grilles form the back bone of a standard offering that will meet any application requirements.

## THE END RESULT

The Parker H. Petit Science Center is the first of many planned enhancements to develop the surrounding area. Georgia State University has positioned itself to raise their profile within the scientific community. This new facility will definitely not only attract new students, but new instructors who are on the brink of making new discoveries and are only hampered by the facilities in which they work.



## PROJECT - ASU BIODESIGN INSTITUTE BUILDING A

Tempe, AZ

CLIENT - ARIZONA STATE UNIVERSITY

LEAD ARCHITECT - GOULD EVANS

ASSOCIATE ARCHITECT - LORD, AECK & SARGENT

ENGINEER - NEWCOMB & BOYD

CONSTRUCTION - SUNDT CONSTRUCTION

LEED CERTIFICATION - LEED GOLD CERTIFIED



### ABOUT THE PROJECT

Considered by most as the “lab of the future,” The ASU BioDesign Institute is a massive multi-building learning and research center built to meet the demands of an ever-changing world. Buildings A & B encompass 350,000 square-feet of award-winning, state-of-the-art LEED-certified space. The Biodesign Institute represents the State of Arizona’s largest investment in bioscience-related research. Arizona State University is the first university in the U.S. to create an interdisciplinary research institute solely devoted to bio-inspired innovation principles. The three major areas in which The Bio-design Institute is working to make a difference are: biomedicine & health outcomes, sustainability and security. This framework allows the Institute to address these critical global challenges by creating “use-inspired,” as well as “bio-inspired” solutions.





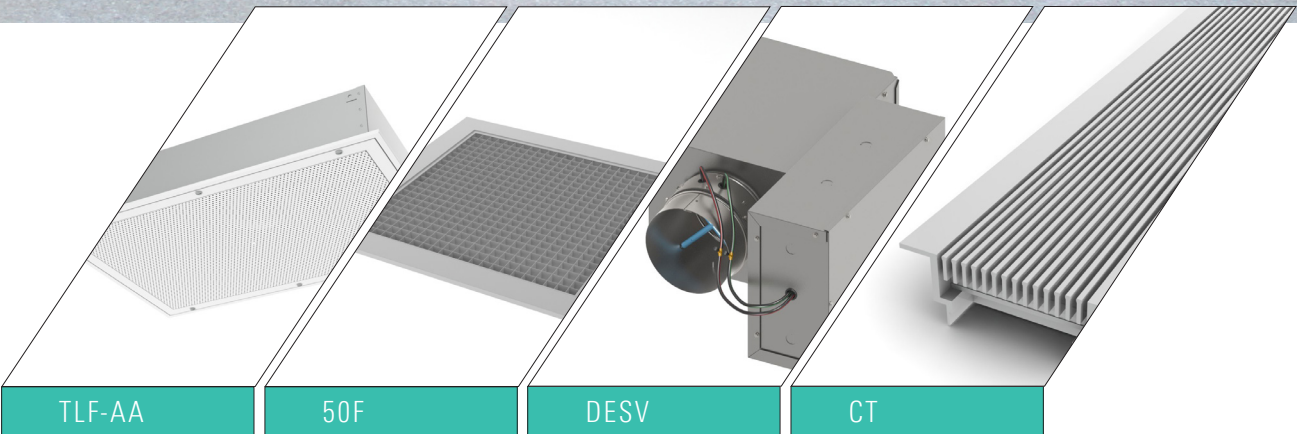

TLF-AA

50F

DES

CT

## FEATURED PRODUCTS





ASU BIODESIGN INSTITUTE  
interior photos

Building A achieved a LEED NC 2.2 Gold Certification after it was built. Designed with Green Building concepts in mind, Building A is filled with sustainable elements. Some of the green elements featured are the use of public transportation. The university encourages all to take advantage of alternate transportation by offering free passes for public service, has several bike racks spread throughout campus and many showers in all the buildings. It also makes excellent use of the abundance of natural light provided. Building A has an impressive atrium that spans the entire space. Instead of having several walls to divide offices and labs, the facility utilizes glass so that light easily penetrate the building. This also offers impressive views of the surrounding landscape while saving energy. Other Green Building elements are the state-of-the-art storm drain system and the use of a reflective roof membrane to reduce the effect of the heat island.

### THE TITUS SOLUTION

The BioDesign Institute has several air distribution products from Titus ranging from grilles and diffusers to terminal units. Our laminar flow diffusers, models TLF-AA and TLF-SS, are the industry standard for unidirectional flow. TLF diffusers can be used to create clean zones by positioning the diffuser directly over the area to be washed with clean air. They are also used in most operating rooms as the center diffuser. The vertical piston of air created by the TLF is used to discharge clean air over the patient during operations. The Titus CT linear bar diffusers are designed for both heating and cooling



applications, supply as well as return. They are available in eight different core styles plus a wide selection of frames and borders. These diffusers can be used for ceiling, side wall, or sill installations. Accessories such as directional blades, dampers, blank-offs, access doors and mitered corners make these diffusers even more versatile.

Single Duct terminals are the fundamental building blocks for Variable Air Volume (VAV) systems. Their primary function is to regulate airflow to a zone, in response to zone temperature requirements. The Titus DESV is unique as it incorporates many design features that increase performance, decrease service and installation costs, and offer increased value, over and above this basic function. This unit also contains a standard AeroCross™ multi-point center averaging velocity sensor. The 50F is an Eggcrate grille. It has the highest free area of any return grille. These grilles are available with an aluminum border and aluminum grid; steel border and aluminum grid; or entirely stainless steel construction. It is offered in ½ x ½ x ½-inch, ½ x ½ x 1-inch, or 1 x 1 x 1-inch core sizes. The 50F is also available as a filtered return grille.

## THE END RESULT

Winner of the 2006 Lab of the Year by R & D Magazine, the ASU BioDesign Institute is now the benchmark for new research facilities being constructed. The Green Building elements featured throughout all the buildings not only help to save energy, but fosters a unique learning environment for the next generation of researchers and scientists to grow and develop.

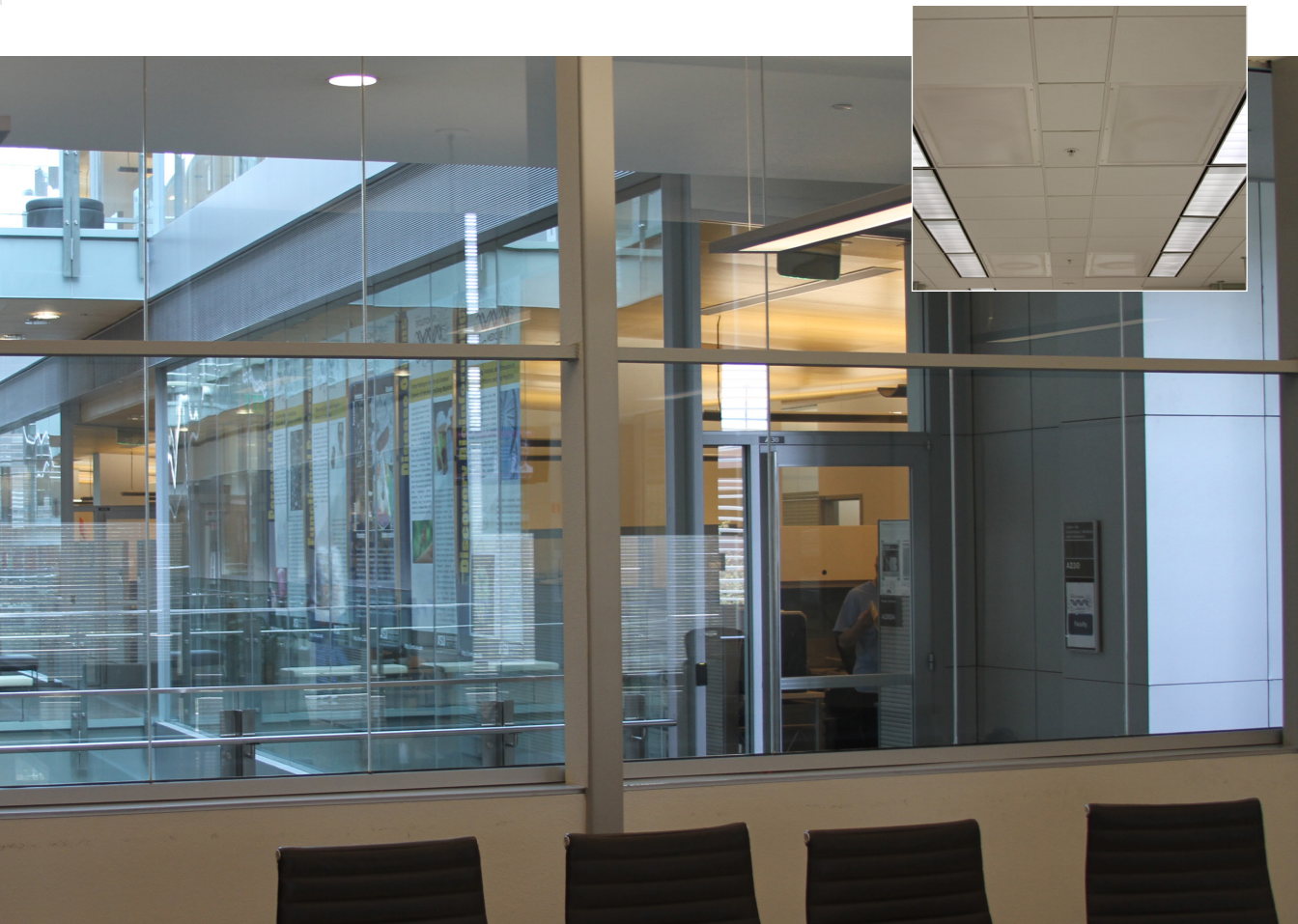



## PROJECT - VAN ANDEL INSTITUTE FOR CANCER RESEARCH

Grand Rapids, MI

CLIENT - VAN ANDEL INSTITUTE

ARCHITECT - RAFAEL VINOLY ARCHITECTS

MEP ENGINEER - WSP FLACK + KURTZ

LAB CONSULTANT - RESEARCH FACILITIES DESIGN (RFD)

CONSTRUCTION - HUNT CONSTRUCTION

LEED CERTIFICATION - LEED PLATINUM CERTIFIED



### ABOUT THE PROJECT

The Phase II addition of the Van Andel Institute for Cancer Research opened on December 8, 2009. It's opening brought hope not only for the many cancer patients seeking cures, but the many jobs will definitely boost the economy in the city. This LEED Platinum Certified facility is located directly to the west of the existing structure. Spanning eight-stories high and totaling 240,000 square feet, the new addition triples the existing laboratory space and affords researchers the opportunity to find cures all types of cancers.

The new building features many energy efficient element. Some of the Green Building design principles utilized were photovoltaic panels, heat recovery systems, low-flow water fixtures that reduce water usage by 30%, and a 27,000-gallon rainwater storage tank. Additional concepts used were





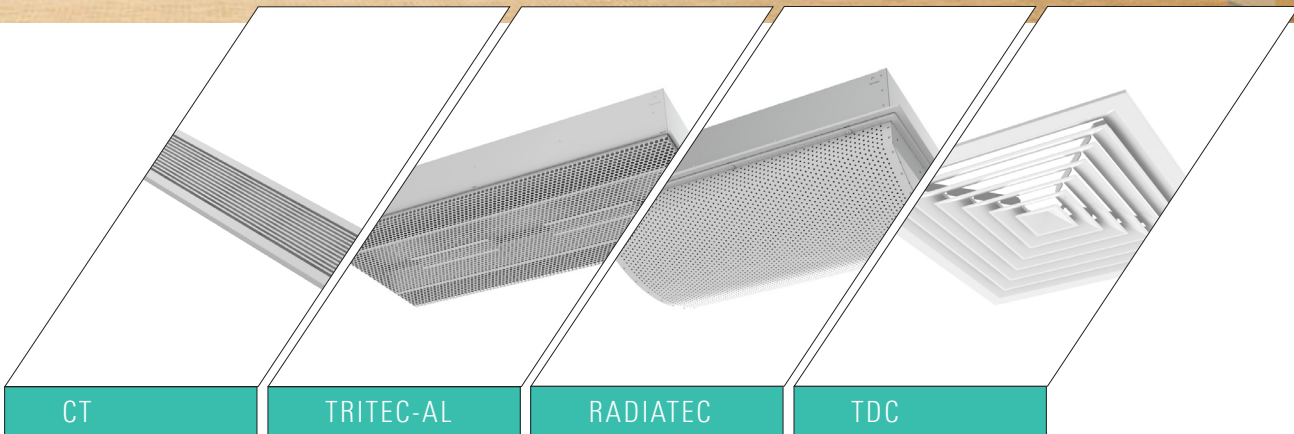

FEATURED PRODUCTS



VAN ANDEL INSTITUTE  
interior photos

installing a lab air sampling and control system, lighting controls, using a glass roof design and open floor plans to maximize the abundance of natural light. The architects also used locally-manufactured materials in the construction process that reinforced their commitment to sustainability.

### THE TITUS SOLUTION

To meet the needs of this new expansion project, Titus supplied many different air distribution solutions. To meet the needs of the additional laboratory spaces, Titus supplied the RadiaTec and TriTec diffusers. The RadiaTec is a dome faced radial diffuser and the TriTec-AL is a rectangular radial diffuser with an aluminum backpan. Both units work well in critical environment applications by diluting airborne contaminants with high-volume, low-velocity airflow to displace impurities. The airflow patterns are designed to produce a uniform pattern to prevent dead spots where contaminants can linger. They are an excellent choice for Class 1,000 to 100,000 rooms.

In areas where air distribution needs did not require a critical environment solution, the TDC and the CT were featured. TDC diffusers handle an unusually large amount of air for a given pressure drop and noise level. Their pleasing appearance harmonizes with various architectural details, especially in modular ceiling systems. CT linear bar diffusers are designed for both heating and cooling applications, supply as well as return. Available in eight different core styles plus a wide selection of frames and borders, these diffusers can be used for ceiling, side wall, or sill installations. Accessories





such as directional blades, dampers, blank-offs, access doors and mitered corners make these diffusers even more versatile.



## THE END RESULT

The Van Andel Institute provides education, biomedical research and hope for the many people throughout the world with cancer. Their new facility only increases their abilities to one day find a cure for the many types of cancer that exist.



## PROJECT - PURDUE UNIVERSITY BIRCK NANOTECH. CENTER

West Lafayette, IN

CLIENT - PURDUE UNIVERSITY

ARCHITECT - HDR ARCHITECTS

CONTRACTOR - PEPPER CONSTRUCTION

LEED CERTIFICATION - NONE



### ABOUT THE PROJECT

Nanotechnology, a word that can simply be defined as the manipulation of matter on an atomic and molecular scale. Purdue University wanted to delve further into this field to see all of the applications that nanotechnology could be utilized and built an impressive facility for that purpose. In July of 2005, the university opened the Birck Nanotechnology Center in Discovery Park. The 187,000 square-foot facility contains cleanrooms, laboratory space, special low vibration rooms that are used for nanostructure research, and other vital areas needed for the advancement of nanotech research.

### THE TITUS SOLUTION

Working with critical environment projects is nothing new to Titus. We have an extensive history of success in applications similar to this. We were able to





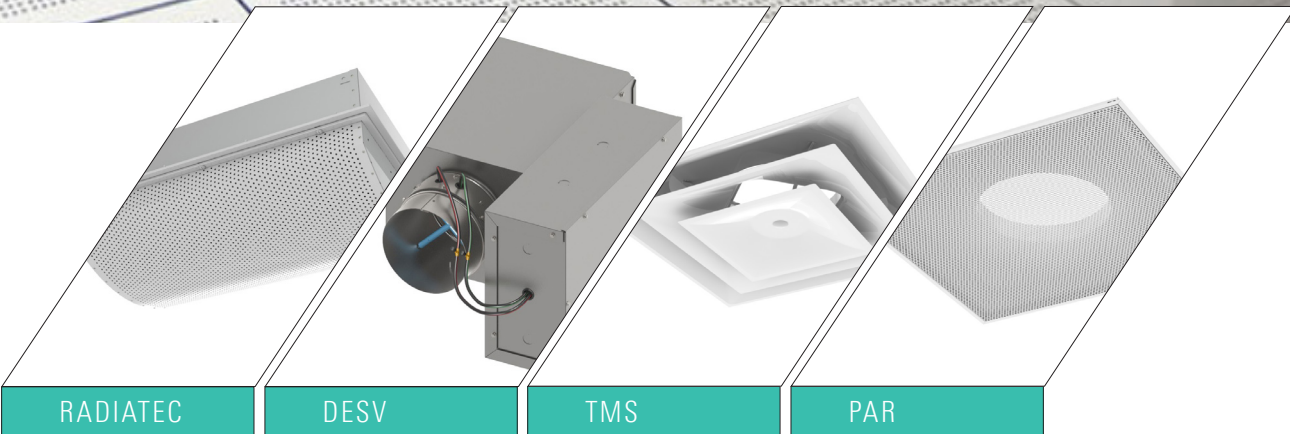

RADIATEC

DESV

TMS

PAR

### FEATURED PRODUCTS



BIRCK NANOTECHNOLOGY  
interior photos

provide several air distribution solutions for the Birck Nanotechnology Center. The products were selected because they provide superior performance, have a clean appearance and also because we have an extensive portfolio of diffusers that are designed specifically for cleanroom applications.

The main critical environment product featured in the center is the RadiaTec diffuser. It is designed to meet the challenge of diluting airborne contaminants by supplying high-volume, low-velocity airflow to displace these impurities. The airflow pattern is designed to produce a uniform pattern to prevent dead spots where contaminants can linger. In addition, the air pattern of the RadiaTec is tighter to the ceiling than competitor models to limit the air pattern penetration into the habitable zone.

Other Titus products featured are the TMS diffuser, the DESV terminal unit and the PAR diffuser. The TMS is a square ceiling diffuser that delivers supply air in a true 360° pattern with low pressure drop. The uniform, nearly horizontal jet from the outer cone maintains effective room air distribution even when the air volume varies over a considerable range. All sizes have three cones, giving a uniform appearance where different neck sizes are used in the same area. The Titus DESV is a digitally controlled single duct terminal unit that is unique as it incorporates many design features that increase performance, decrease service and installation costs, and offer increased value, over and above this basic function. Perforated ceiling diffusers are typically selected to meet architectural demands for air outlets that blend into the ceiling plane.

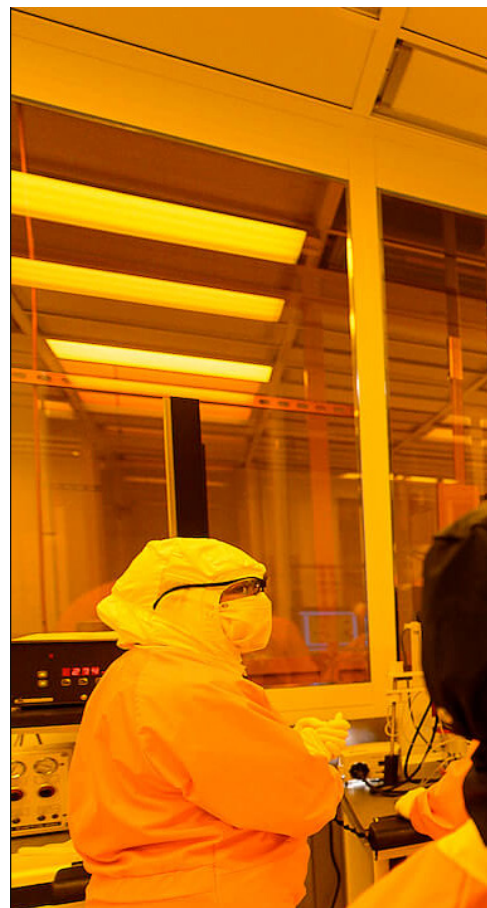



Titus perforated diffusers can be selected for a round pattern to maximize capacity or star pattern to maximize throw. The Titus PAR is a return perforated ceiling diffuser that has the same face and border construction as the supply models, for harmonious appearance in the room.

## THE END RESULT

Since it opened in 2005, the Birck Nanotechnology Center at Purdue University has been striving to delve into all applications of nanotechnology. It's goal is to explore all avenues and hopefully one day soon, unlock new fields of science and technology that can benefit from this emerging scientific field.



## PROJECT - UCLA TERASAKI LIFE SCIENCE BUILDING

Los Angeles, CA

CLIENT - UCLA

ARCHITECT - BOHLIN CYWINSKI JACKSON (BCJ)

ASSOCIATE ARCHITECT - STENFORS ASSOC. ARCHITECTS

CONSTRUCTION - KHS&S

GENERAL CONTRACTOR - PCL CONSTRUCTION

MASON CONTRACTOR - MASONRY CONCEPTS INC.

LEED CERTIFICATION - LEED SILVER CERTIFIED



### ABOUT THE PROJECT

The new UCLA Terasaki Life Sciences Building opened recently and ushered in a new chapter in the evolution of science education at the university. Consisting of two wings with open laboratories, offices, scholarly activity space, and building support spaces on five floors, the new new facility will be the foundation for the next phase of biomedical research. The 175,000 square-foot structure is supported by a cast-in-place concrete frame with flat-slab floor decks and is the new home of the Biological Sciences Department. Divisions within the department include Molecular Studies; Cell and Developmental Biology; Physiological Science; and Biology, Ecology and Evolution. The design team also built this lab building to attain LEED certification.





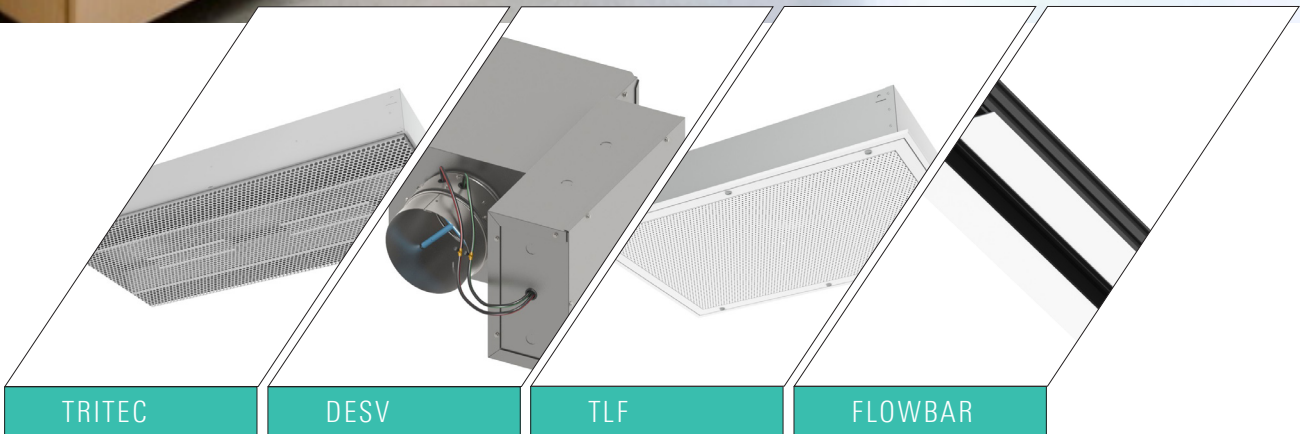

TRITEC

DESV

TLF

FLOWBAR

## FEATURED PRODUCTS



TERASAKI LIFE SCIENCE BLDG.  
interior photos

## THE TITUS SOLUTION

Titus was able to provide many air distribution solutions for this project. The products were selected due to their ability to provide superior performance while blending into the overall design of the building.

The new lab building utilizes a couple of Titus' best critical environment solutions - the TriTec and TLF diffusers. Titus TriTec diffusers are designed to meet the challenge of diluting airborne contaminants by supplying high-volume, low-velocity airflow to displace these impurities. The airflow pattern is designed to produce a uniform pattern to prevent dead spots where contaminants can linger. It is an excellent choice for Class 1,000 to 100,000 rooms. TLF diffusers can be used to create clean zones by positioning the diffuser directly over the area to be washed with clean air.

The Titus DESV is a digitally controlled single duct terminal unit that is unique as it incorporates many design features that increase performance, decrease service and installation costs, and offer increased value, over and above this basic function. The Titus FlowBar is an architectural linear diffuser that maximizes engineering performance. It's outstanding performance allows higher airflows than conventional linear diffusers, with lower noise levels, making it ideal for high profile designs. The wide assortment of slot widths allow for more CFM per linear foot while minimizing noise and pressure loss. The Flowbar system is available in continuous linear, incremental linear and square configurations and can be custom curved as well.





## THE END RESULT

The new Terasaki Life Science Building fulfills a direct need that was lacking at the university. It provides a state-of-the-art facility for scientists, students and researchers to unwrap and discover more about the science of life. New innovations and potentially life altering secrets have the possibility of being unlocked now that key personnel have been given the tools needed.



C A S E S T U D Y  
**PROJECTS**



ADVANCING THE SCIENCE OF AIR DISTRIBUTION

605 Shiloh Rd.  
Plano, Texas 75074  
(ofc): 972.212.4800  
(fax): 972.212.4884  
(web): [www.titus-hvac.com](http://www.titus-hvac.com)